

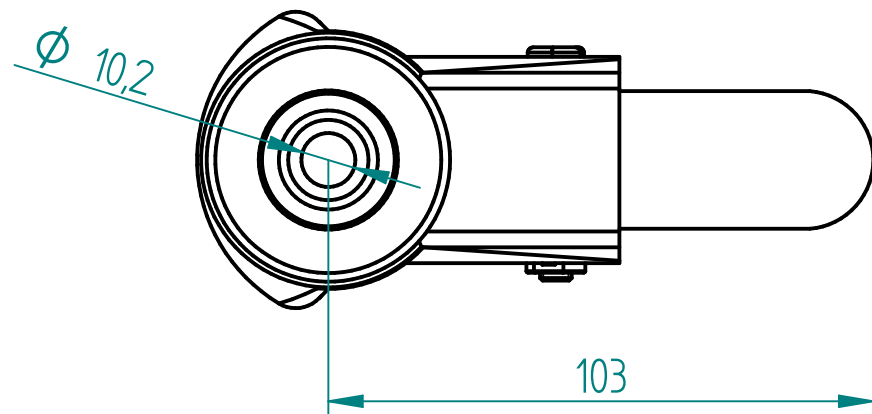

SECTION A-A

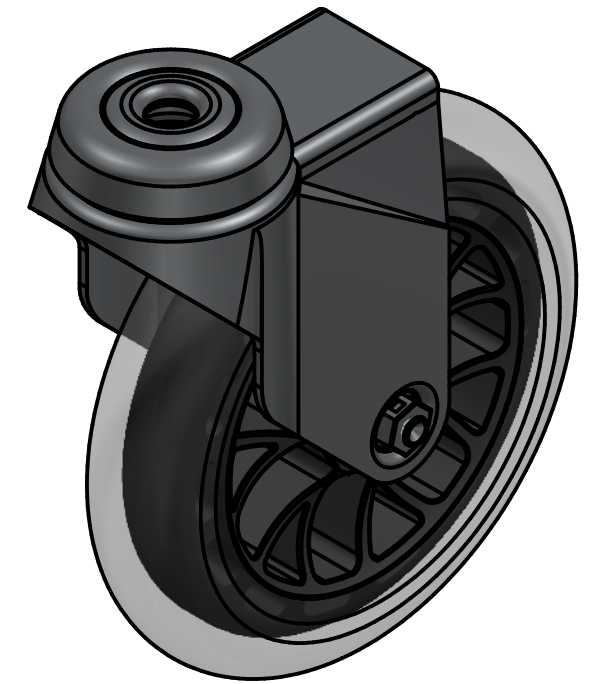

Load Capacity : 60Kg, for speed up to 4Km/h
(according to EN12530:1998)

 PRODUCTION OF INSTITUTIONAL CASTORS AND WHEELS THESSALONIKI - GREECE This drawing is the property of RODA S.A. It must neither be reproduced in any manner nor shall it be submitted to third parties or competitors without our written consent	PERMIS. VARIATIONS:		PART No:	
	SURFACE FINISH:		UNF. DIM.:	
				MATERIAL : Swivel castor, steel support, bolt hole Ø10mm. Wheel 120x26mm, non marking PU (85ShA), ball bearing.
		DESIGNED 13/7/2021 ALISANDRATOS S.	PART DESCRIPTION : <p style="text-align: center;">M125PUSHS</p>	
		DRAWN 13/7/2021 ALISANDRATOS S.		
		CHECKED 13/7/2021 SAATSOGLU H.		
C3			QUANTITY SCALE	DRAWING SHEET No.
B2				
A1			REPLACE	GEN. DWG. NUM. :
A/A				