

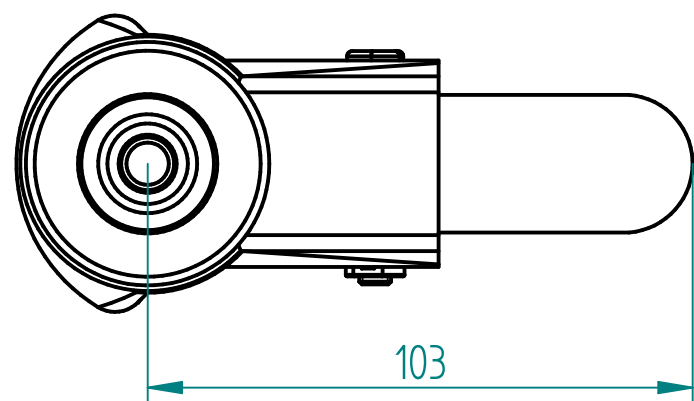

SECTION A-A

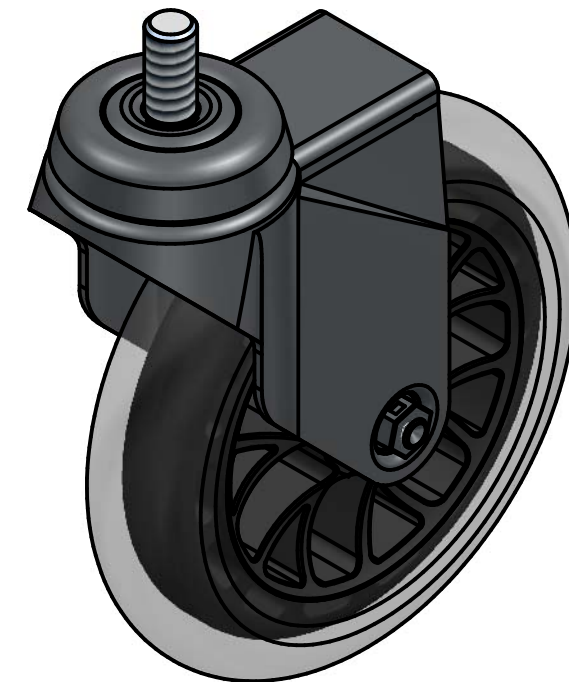

Load Capacity : 60Kg, for speed up to 4Km/h
(according to EN12530:1998)

 PRODUCTION OF INSTITUTIONAL CASTORS AND WHEELS THESSALONIKI - GREECE	PERMIS. VARIATIONS:		PART No:		
	SURFACE FINISH:		UNF. DIM.:		
This drawing is the property of RODA S.A. It must neither be reproduced in any manner nor shall it be submitted to third parties or competitors without our written consent	DESIGNED	13/7/2021	ALISANDRATOS S.	MATERIAL : Swivel castor, steel support, bolt stem M10x20mm. Wheel 120x26mm, non marking PU (85ShA), ball bearing.	
	DRAWN	13/7/2021	ALISANDRATOS S.		
	CHECKED	13/7/2021	SAATSOGLU H.		
PART DESCRIPTION : <p style="text-align: center;">M125PUSBS</p>					
C3				DRAWING	SHEET No.
B2					
A1				QUANTITY	SCALE
A/A					